

SHOCK ABSORBING

4100 SERIES

Medium-Heavy Duty
Shock Absorbing

Load Capacity: 350 to 800 lbs.

Quality Features

Designed to reduce noise and isolate medium heavy loads from shock as they are rolled over rough or irregular surfaces. Upper swivel raceway consists of 3/8" hardened steel top plate and base plate that is machined to close tolerances and dimensions. Yoke legs are continuously welded to yoke base for added strength and endurance. Upper raceway is permanently assembled with neoprene grease seal. Bottom raceway is covered with a metal grease seal cap that is press fit then secured with epoxy. Pressure fitting is provided for lubrication using conventional grease guns. Standard finish is Laguna Blue.

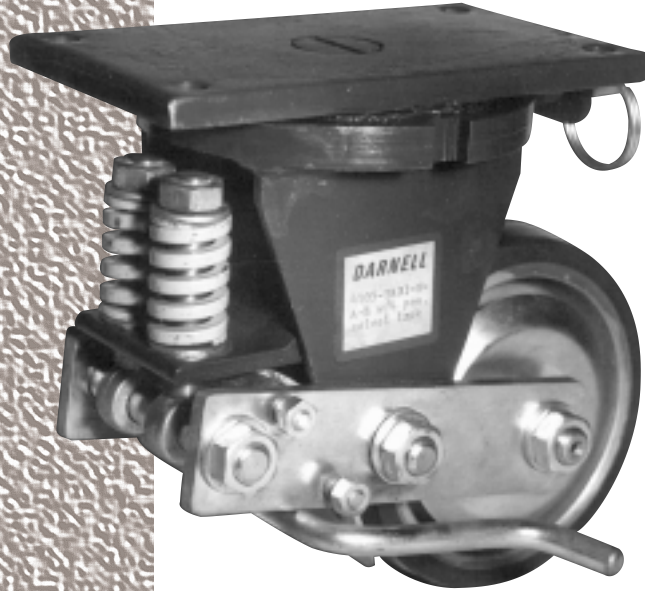

TOP PLATE

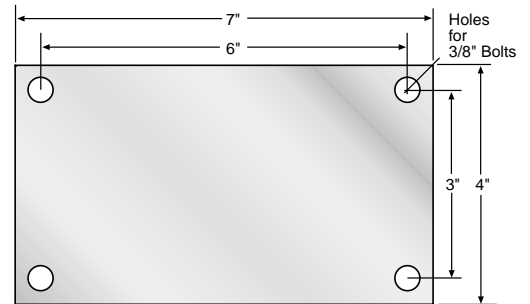

SWIVEL BEARING RACEWAY- 4100 SERIES

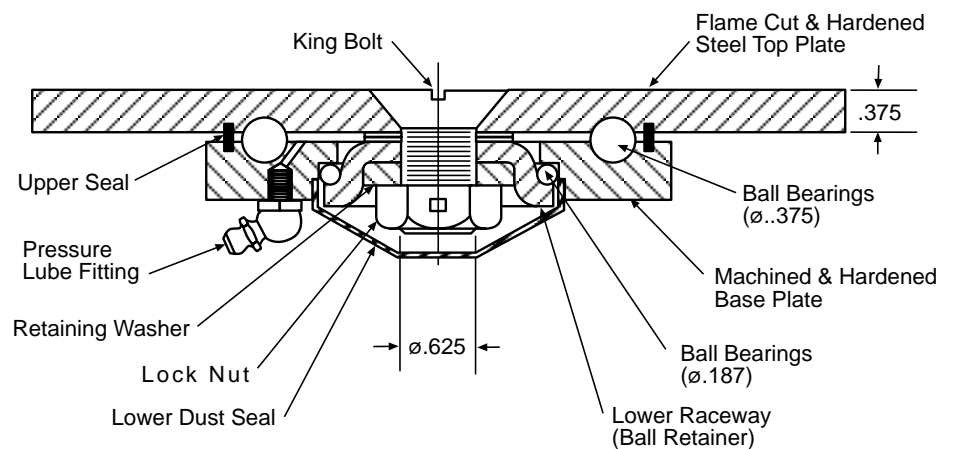

Wheel Selection

NEOPRENE RUBBER

HI-CAP NEOPRENE

CAST IRON HUB

MOLD-ON POLYURETHANE



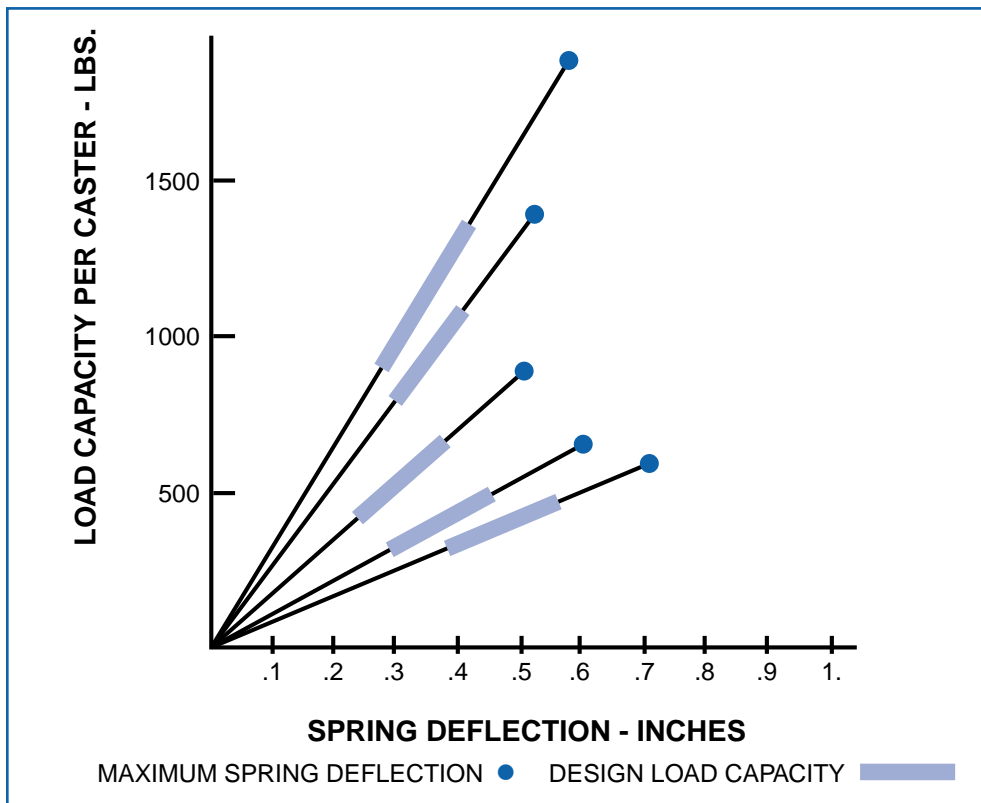

BRAKES

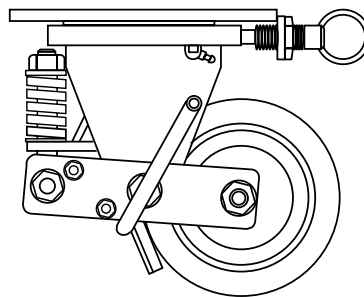
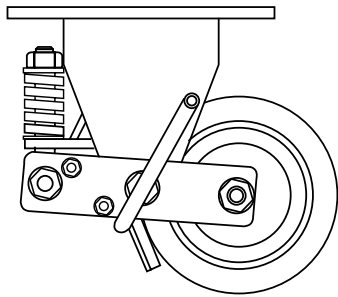

Wheel Brake

Operates by a foot pedal lever that has a rubber brake pad to form a positive brake action when the brake lever is pressed down to engage. To restore back to the normal position, simply reverse the action to disengage the brake. Easy to operate and trouble free.

Four Position Swivel Lock and Wheel Brake

A horizontal four position swivel lock with a spring-loaded plunger to securely hold the swivel in the slotted position desired. Plunger can be put into a neutral position for free swiveling action.

Diameter	Tread Width	Load Capacity	Wheel Material	Bearing	Swivel Part Number	Rigid Part Number	Approx. Weight	Overall Height	Swivel Radius
5	1 7/8	350	NEOPRENE RUBBER	ROLLER	4105-TDN	4105-TRDN	14-1/2	7-1/2	5-1/8
		440	HI-CAP NEOPRENE	ROLLER	4105-TKN	4105-TRKN			
		800	POLYURETHANE / CAST IRON HUB	ROLLER TAPERED ROLLER	4105-TADI-M-CI 4105-YADI-M-CI	4105-TRADI-M-CI 4105-YRADI-M-CI	14		
6	1 7/8	400	HI-CAP NEOPRENE	ROLLER	4106-TKN	4106-TRKN	17-1/8	8	5-5/8
			NEOPRENE RUBBER		4106-TDN	4106-TRDN			
		800	POLYURETHANE / CAST IRON HUB	ROLLER TAPERED ROLLER	4106-TADI-M-CI 4106-YADI-M-CI	4106-TRADI-M-CI 4106-TRADI-M-CI	15		
8	1 7/8	475	NEOPRENE RUBBER	ROLLER	4108-TDN	4108-TRDN	19	9-7/8	7-1/8
		600	HI-CAP NEOPRENE	ROLLER	4108-TKN	4108-TRKN			
		800	POLYURETHANE / CAST IRON HUB	ROLLER	4108-TADI-M-CI	4108-TRADI-M-CI	17		
			POLYURETHANE / CAST IRON HUB	TAPERED ROLLER	4108-YADI-M-CI	4108-YRADI-M-CI			